

CENTAUR T2G.10

Two-Tier Gas Assisted Lift Cycle Racks



Cycle Racks shown are CENTAUR Two TG2.12s
Two Tier Cycle Rack - 24no. Cycles

CENTAUR T2G models have the gas-assisted lift and lower system on upper tier bike trays. All steel construction with hot-dip galvanised coating throughout for maximum durability in external environments.

CENTAUR T2 two-tier cycle racks are designed to achieve the maximum number of cycles stored per square metre, with seven fitting into just 6.6m²! Two-tier cycle racks are specified for use in internal cycle storage rooms, external cycle storage buildings, cycle shelters and canopies, in locations such as public transport terminals, inner-city offices, hospitals and universities where large numbers of cycles need to be stored and the available footprint is a significant constraint.

Designed and manufactured in the UK by Streetspace, the CENTAUR T2 is constructed around an immensely strong fully-welded steel chassis which also forms the support frame for the upper tiers. Galvanised steel wheel trays provide accurate tracking for each cycle with both wheel wells formed in the tray and end constraint bars holding the cycle secure. Integral locking frames enable different cycle sizes to be secured reliably.



CENTAUR T2G.10 Unit Dimensions

(A)	Width:	1965mm
(B)	Recommended Minimum Width For Operation:	2251mm
(C)	Depth:	2013mm
(D)	Recommended Minimum Depth For Operation:	3700mm
(E)	Height:	1907mm
(F)	Recommended Minimum Height Clearance:	2550mm

Storage: 10no. Cycles

PLEASE NOTE: Product dimensions given are correct at time of publishing April 2023. All dimensions are in millimetres and capacities in litres and don't form any part of the contract.

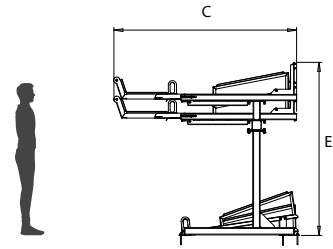
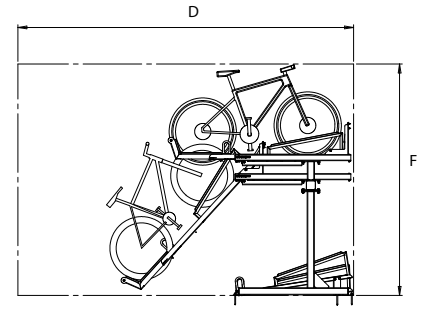
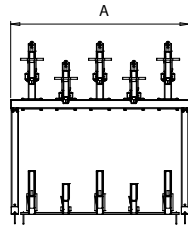
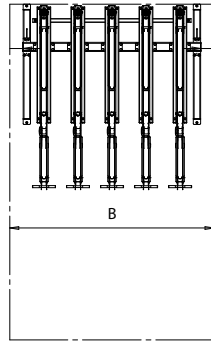

The content of this document is for your general information and use only. Specifications are subject to change without notice. Images are for illustrative purposes only. Specifications correct at time of print April 2023.