



CENTAUR CS 10

Single Row Asymmetric
Cycle Shelters

Cycle Shelter Shown is a Streetspace Centaur CS 8 Single Row Asymmetric Cycle Shelter - HD Galvanised Finish (Shelter/Stands) Roof Fix Stands - 8 Cycles

A clear-span, open canopy type structure, **CENTAUR CS** cycle shelters are designed for weather protection that adds architectural value with an asymmetric radius roof and centrally fixed radius steel support structure.

CENTAUR CS can be used as either a standalone shelter or as a series of shelters forming a cycle compound and is typically specified where the site is secure and focused areas of weather protection are required along with clear lines of sight and a limited overall visual impact.

CENTAUR cycle shelters are UK manufactured by Streetspace and the all-steel framework has a hot dip galvanised finish as standard with optional colour powder coated finishes available. UV protected multiwall polycarbonate roof panels with aluminium glazing system combine clean aesthetics with a long service life.

Produced in standard 4100mm and 5100mm shelter widths, CENTAUR CS provides 2700mm cover width for 10 or 12 cycles with standard 'sheffield' type stands. Bespoke dimensions can be accommodated as a special build. The radius steel support structure has a central base plate design enabling either surface fix or subsurface ground fixings to be accommodated. Browse our full range of cycle stands.

For cycle compound configurations, CENTAUR CS can be specified alongside the larger CENTAUR CLS model including the addition of 'flying roof' sections between shelters for increased weather protection.



CENTAUR CS 10 Unit Dimensions

(A) Top Depth: 2703mm	(B) Base Depth: 500mm	(C) Top Width: 4010mm	(D) Base Width: 4180mm
(E) Height Front: 2363mm	(F) Height Rear: 1760mm	Storage: 10no Cycles	PLEASE NOTE: Product dimensions given are correct at time of publishing October 2022. All dimensions are in millimetres and capacities in litres and don't form any part of the contract.

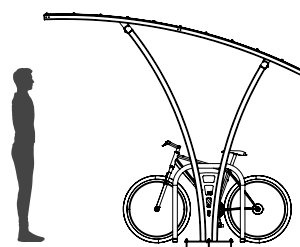
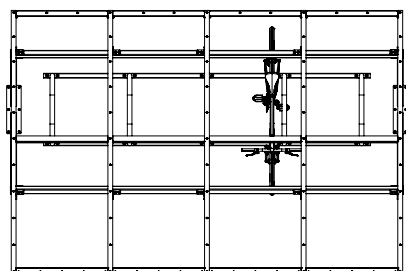
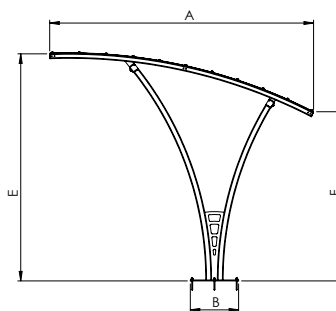
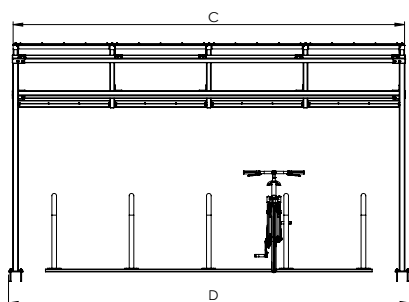

Steel Finish Options



Hot Dip
Galvanised

Colour Polyester
Powdercoat

Stand Fixing Options



Rail Fix (Toast Rack)

Stands are surface mounted to ground fix steel rails.



Baseplate

Integral base plates for individual ground fixing.

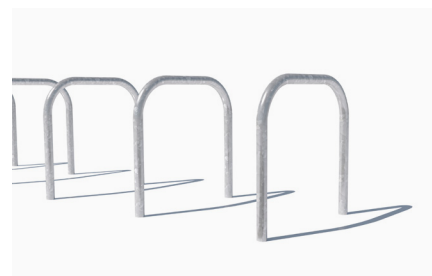

Root Fix

Stands are cast into concrete below ground.

The content of this document is for your general information and use only. Specifications are subject to change without notice. Images are for illustrative purposes only. Specifications correct at time of print October 2022.

Streetspace Ltd.

Streetspace Ltd, Lympe Industrial Park, Otterpool Lane, Hythe, Kent CT21 4LR
e: enquiries@streetspacegroup.co.uk | t: 01227 200404 | www.streetspacegroup.co.uk/
STREETSPACE LIMITED, Registered in England and Wales: 10175199



19017385



202497/A/0001/UK/En

